

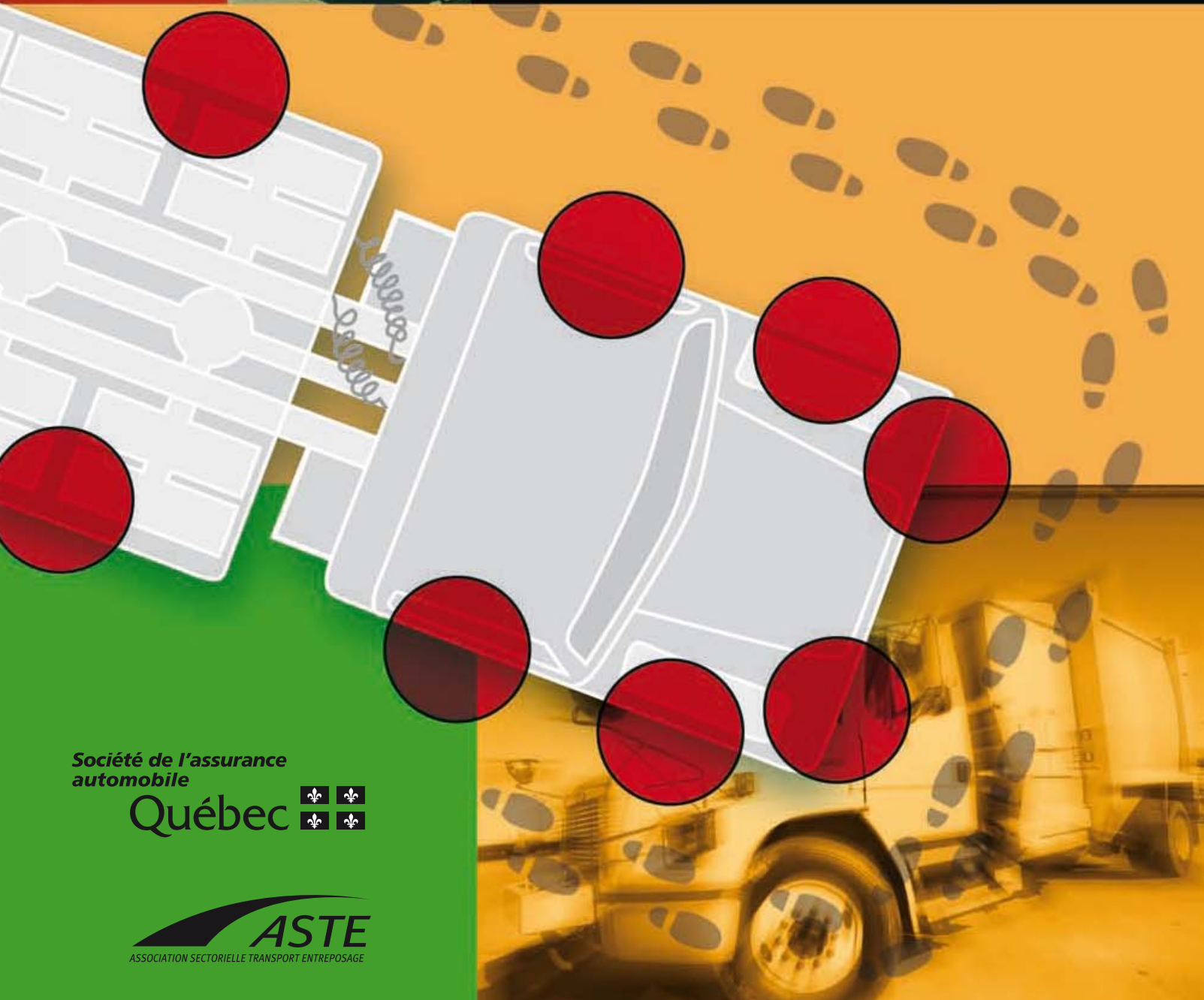

 Inspect
 Before You
 Go

DAILY PRE-TRIP INSPECTION GUIDE



Société de l'assurance automobile

Québec 

ASTE
ASSOCIATION SECTORIELLE TRANSPORT ENTREPOSAGE

Table of Contents

INTRODUCTION	3	● Section 11 – Suspension	44
DAILY PRE-TRIP INSPECTION	5	• Metal spring suspension	44
• Goal	5	• Air spring suspension	45
• What a pre-trip inspection is	5	● Section 12 – Chassis Frame	47
• Vehicles subject to pre-trip inspection	7	● Section 13 – Trailer Hitch (Coupling Device)	48
• Vehicles exempt from pre-trip inspection	7	• Tractor-semitrailer	48
• Vehicle components to be checked	8	• Truck-trailer	50
• Pre-trip inspection report	9	● Section 14 – Load Securement	51
• Sample report for reproduction	12	OCCUPATIONAL INJURIES	52
• Who performs the pre-trip inspection?	13	OCCUPATIONAL HAZARDS OF PRE-TRIP INSPECTIONS AND HOW TO AVOID INJURY	53
• Pre-trip inspection procedure	14	When checking under the hood	53
• When to conduct the pre-trip inspection	16	When getting in and out of your vehicle	55
• Special provisions	16	When checking outside the vehicle	56
• Establishing a routine	18	When inspecting the trailer hitch	57
• Obligations of heavy vehicle owners and operators	20	PRE-TRIP INSPECTION IN CANADA AND THE UNITED STATES (addresses of responsible organizations)	58
• Obligations of heavy vehicle drivers	21	ASSOCIATION SECTORIELLE TRANSPORT ENTREPOSAGE (ASTE)	59
COMPONENTS AND SYSTEMS SUBJECT TO INSPECTION	23	REGIONAL OFFICES OF THE COMMISSION DE LA SANTÉ ET DE LA SÉCURITÉ DU TRAVAIL (CSST)	60
● Section 1 – Service Brakes	24	FOR FURTHER INFORMATION	61
• Service brakes – air brake system	24	To find out which publications are available from the Société de l'assurance automobile du Québec, click on: www.saaq.gouv.qc.ca/documents/documents_pdf/index.html	
• Service brakes – hydraulic braking system	27	This is not a text of law. For any question of a legal nature, please refer to the <i>Highway Safety Code</i> and attendant regulations.	
● Section 2 – Parking brake	29	Version française disponible sur demande.	
● Section 3 – Steering System	30		
● Section 4 – Horn	32		
● Section 5 – Windshield Wipers and Washer	33		
● Section 6 – Outside Mirrors	34		
● Section 7 – Emergency Equipment	35		
● Section 8 – Lights and Signals	36		
• All vehicles	38		
• School buses	39		
● Section 9 – Tires	41		
● Section 10 – Wheels	43		

Introduction

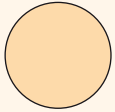
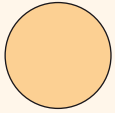

A pre-trip or pre-departure inspection, is first and foremost a matter of highway safety. Properly done, it can prevent certain types of accidents caused by vehicles that are not in good mechanical condition and maybe even save lives—including yours!

Under the current regulations, you are required to conduct a visual and auditory inspection of certain vehicle components before setting out. Responsibility for management of pre-trip inspections falls to the vehicle owner or operator.

This guide sets forth the current regulations regarding pre-trip inspections and the vehicle parts covered by these regulations. It proposes a preventive approach that will enable you to identify certain minor and major defects and inform the vehicle owner or operator thereof.

It also discusses the occupational hazards inherent in pre-trip inspections and tells you how to avoid injury. Finally, it provides the addresses and telephone numbers of various organizations you can contact to obtain information on the regulations in force elsewhere in Canada and in the United States.

The information contained in this guide cannot be used for legal purposes. For this, you must refer to the relevant sections of Québec's Highway Safety Code or the Act respecting owners and operators of heavy vehicles.

REVISED EDITION COORDINATOR

Michel Dupuis

Société de l'assurance automobile du Québec

CONTRIBUTORS

Langis Lafrance

Association sectorielle transport et entreposage

Stéphane Patenaude

Association sectorielle transport et entreposage

Lyse Pelletier

Société de l'assurance automobile du Québec

Jacques Richard, Eng.

Société de l'assurance automobile du Québec

Jean-Hugues Côté

Société de l'assurance automobile du Québec



Daily pre-trip inspection

*Mechanical defects are a factor in 13% of all heavy vehicle accidents.**

To conduct a pre-departure check, you need:

Under the Act respecting owners and operators of heavy vehicles "heavy vehicle" means:

Heavy vehicle owner:

Heavy vehicle operator:

GOAL

To keep vehicles in poor mechanical condition off the road, and thereby reduce accidents.

WHAT A PRE-TRIP INSPECTION IS

A pre-trip inspection is a sight and sound check of a heavy vehicle's accessible parts designed to ensure that the vehicle is safe to drive. It enables the person responsible for the vehicle to repair any defects before the vehicle is put on the road.

REQUIRED TOOLS FOR A PRE-TRIP INSPECTION

- a flashlight (in case it is dark);
- clean rags and work gloves;
- where necessary, a tool to open reservoirs in vehicles with power brakes and power steering;
- a pressure gauge to measure air in tires.

IMPORTANT DEFINITIONS

- a) a road vehicle or a combination of road vehicles, within the meaning of the Highway Safety Code, whose gross vehicle weight rating (GVWR) is 4,500 kg or more;
- b) a minibus or a tow truck, within the meaning of that Code, regardless of net mass;
- c) a road vehicle subject to the Transportation of Dangerous Substances Regulation.

Any person or business that registers a heavy vehicle in his/its name, either as an owner or lessee, for one year or more, or who acquires such a vehicle pursuant to a leasing contract.

Any person or business that uses a heavy vehicle for commercial or professional purposes, i.e.:

- the transportation of goods or passengers, or
- vehicle assistance; or
- personal ends; or
- for equipment transport.

The above definition applies whether the operator owns the vehicle(s) used or operates it/them pursuant to a leasing contract (regardless of whether the services of a driver are supplied by the less or) or a service contract.

* Gou, Michel. *Résumé de l'étude sur l'incidence de l'état mécanique des poids lourds sur la sécurité routière*. École Polytechnique, Montréal, 1997, p. XIV.



Radius of 160 km:

A distance of 160 km as the crow flies, calculated from the driver's home base using a geographic map.

Home base:

The driver's usual place of work or where the driver works for at least four consecutive days (e.g. job site).

Work shift:

The period of time during which a driver is on duty. This period is normally preceded and followed by at least 8 consecutive hours of rest. Unless he changes vehicles, the driver is not required to conduct another inspection before starting out again.

Minor defect:

A mechanical defect that does not pose an immediate threat to the safety of road users but that may deteriorate rapidly. The defect must be repaired within 48 hours of being discovered and entered in the pre-trip inspection report.

Major defect:

A mechanical defect that poses an immediate threat to the safety of road users. The vehicle may not be put back into operation until the defect has been repaired.

Tool vehicle:

A road vehicle, other than a vehicle mounted on a truck chassis, with a low design speed and whose work station is an integral part of the driver's cab (e.g. **crane not mounted on a truck chassis, grader, roller, lift truck, backhoe loader**).

Equipment transport vehicle:

A vehicle with a gross vehicle weight rating of 4,500 kg or more that is used solely to transport equipment permanently attached to it and that cannot be used to transport other goods (e.g. **well drill, concrete pump, compressor, crane mounted on a truck chassis**).



A PRE-TRIP INSPECTION IS...

- A)** A comprehensive inspection of all vehicle parts?
- B)** A sight and sound check of a vehicle's accessible parts?

Answer: B



The following vehicles whose gross vehicle weight rating (GVWR) is 4,500 kg or more:

Combinations of road vehicles: (the pre-trip inspection must be carried out on the ALL the vehicles in these combinations):

The following vehicles, regardless of their net weight:

VEHICLES SUBJECT TO PRE-TRIP INSPECTION

- Buses;
- Trucks, including road tractors;
- Trailers and semitrailers;
- Equipment transport vehicles (see definition above);
- Emergency vehicles (e.g. ambulance, fire truck, emergency response vehicle).
- Composed of at least one vehicle whose gross vehicle weight rating (GVWR) is 4,500 kg or more;
- The combination of vehicles has gross vehicle weight rating of less than 4,500 kg and is used to transport dangerous substances on requiring placards warning of danger.
- Tow trucks;
- Minibuses;
- Road vehicles transporting dangerous substances in sufficient quantity to require placards warning of danger.

VEHICLES EXEMPT FROM PRE-TRIP INSPECTION

- Heavy vehicles used during disasters (either to go to or to return from the site);
- Heavy vehicles used by a natural person for personal ends, i.e. other than for commercial or professional purposes (e.g. truck used to move household goods, motor home, recreational vehicle);
- Straight trucks with two or three axles used primarily for transporting unprocessed farm, forest or fishery products, provided the carrier is also the producer. For example a potato grower who delivers his own product. This exemption is also valid for to the same vehicle on the return trip provided that it is empty or used to transport products used farming, forestry or a natural body of water;
- A combination of vehicles a gross vehicle weight rating of less than 4,500 kg, and is not carrying dangerous substances in sufficient quantity to require placards warning of danger;
- Tool vehicle, that is, a road vehicle, other than a vehicle mounted on a truck chassis, whose workstation is an integral part of the driver's cab (e.g. crane, grader, roller, lift truck, backhoe loader);
- Vehicles with a gross vehicle weight rating of less than 4,500 kg carrying an insufficient quantity of dangerous substances to require placards warning of danger;
- Farm tractors and farm machinery within the meaning of the Regulation respecting vehicle registration, and farm trailers within the meaning of the Regulation respecting safety standards for road vehicles;
- Fire trucks belonging to a municipality with fewer than 25,000 inhabitants that is not part of an urban community.



Drivers required to conduct an inspection must check the following elements and systems prior to departure:

- Service brakes;
- Parking brake;
- Steering system;
- Horn;
- Windshield wipers and washer;
- Mirrors;
- Emergency equipment;
- Lights and signals;
- Tires;
- Wheels;
- Suspension;
- Chassis frame;
- Trailer hitch (coupling device);
- Load securing devices.

*Given the size and weight of heavy vehicles, a mechanical defect can have serious consequences**



Drivers are responsible for reporting any defects discovered during roadside inspections.

PRE-TRIP INSPECTION REPORT

The driver or maintenance worker who performs the pre-trip inspection must record his observations regarding the vehicle's mechanical condition in an inspection report.

The following information must be recorded in the inspection report.

The date the pre-trip inspection was done

The licence plate number or unit number shown on the registration certificate issued for the power unit and other units making up a combination of vehicles

Identification of defects found during inspection

If no defects are found, check here

Describe the nature of the defect found

Driver's name and signature

Where the inspection is performed by a maintenance crew member, the inspection report must be signed by this person and countersigned by the first driver and any alternate(s)

Pre-trip

Inspection Report

Pre-trip Inspection Report

Date: June 12, 2004

Vehicle licence plate or unit no.: L-12345

Semitrailer licence plate or unit no.: RL 54321

ITEMS TO BE CHECKED:	SATISFACTORY	DEFECTIVE
Service brakes	<input checked="" type="checkbox"/>	<input type="checkbox"/>
Parking brake	<input checked="" type="checkbox"/>	<input type="checkbox"/>
Steering system	<input checked="" type="checkbox"/>	<input type="checkbox"/>
Horn	<input checked="" type="checkbox"/>	<input type="checkbox"/>
Windshield wipers and washer fluid	<input checked="" type="checkbox"/>	<input type="checkbox"/>
Mirrors	<input checked="" type="checkbox"/>	<input type="checkbox"/>
Emergency equipment	<input checked="" type="checkbox"/>	<input type="checkbox"/>
Lights and signals	<input type="checkbox"/>	<input checked="" type="checkbox"/>
Tires	<input checked="" type="checkbox"/>	<input type="checkbox"/>
Wheels	<input checked="" type="checkbox"/>	<input type="checkbox"/>
Suspension	<input checked="" type="checkbox"/>	<input type="checkbox"/>
Chassis frame	<input checked="" type="checkbox"/>	<input type="checkbox"/>
Trailer hitch	<input checked="" type="checkbox"/>	<input type="checkbox"/>
Securing devices	<input checked="" type="checkbox"/>	<input type="checkbox"/>

No defect found during inspection

Remarks (nature of defect): Right headlight does not work

Name of driver: Joe Wise

Driver's signature: [Signature]

Maintenance crew member's signature (bus or ambulance): [Signature]

Operator's or agent's signature, if defects are found

(Duplication authorized)



<p>The pre-trip inspection report informs the vehicle owner and operator of any defects found during the inspection so that the necessary repairs may be made. The following obligations apply:</p>	<p>The pre-trip inspection report is supplied by the operator.</p> <ul style="list-style-type: none">• Drivers must keep the inspection report for the vehicle they are driving in the vehicle during the current day;• Drivers must enter in the inspection report any defects discovered before or during their trip;• Drivers must hand the inspection report in to the operator as soon as they get back to their home base. Where the operator is not the owner of the heavy vehicle, he must forward a copy of the report to the vehicle owner;• Where a defect is discovered, the driver of the vehicle must inform and submit a copy of the inspection report to the operator without delay (<i>e.g. by phone or fax if the defect is discovered during a roadside inspection</i>), and the operator must read and sign it upon receipt;• In the case of a combination of vehicles, an inspection report may be kept for each vehicle or for both (or all three) vehicles together. The licence plate or unit number of each vehicle must be entered in the report, and a copy of the report must be submitted to the owner of each vehicle so that the the necessary repairs are made.
<p>RECOMMENDATION</p>	<p>The SAAQ recommends using separate logs for pre-trip inspections and for driving and duty time. Since the pre-trip inspection report follows the vehicle and the driving and duty time log follows the driver, they will be easier to administer if they are separate documents.</p> <p>However, drivers who so wish may use a single log by entering the information relating to driving and duty time on one side and the information relating to pre-trip inspections on the other. This solution is especially practical where a single driver always drives the same vehicle.</p>



You do not have to complete the pre-trip inspection report if you meet the following three conditions:

- You check the vehicle yourself;
- You are going to be driving within a 160-km radius of your home base; and
- You do not find any mechanical defects during the pre-trip inspection or a roadside inspection.

RECOMMENDATION	The SAAQ recommends that drivers make a habit of always completing the pre-trip inspection report, especially drivers who occasionally travel outside the 160-km radius. The purpose is to ensure regulatory compliance and make the reports easier to manage.
-----------------------	---

Mandatory	Even if you are operating within the 160-km radius, the inspection report must be kept on board the vehicle at all times in case a mechanical defect turns up during the trip.
------------------	---



DRIVERS WHO OPERATE OUTSIDE THE 160-KM RADIUS ARE REQUIRED TO COMPLETE A PRE-TRIP INSPECTION REPORT.

True or False?

Answer: True

A PRE-TRIP INSPECTION REPORT IDENTIFYING ANY DEFECTS FOUND DURING THE INSPECTION MUST BE KEPT IN THE VEHICLE FOR A PERIOD OF SIX DAYS.

True or False?

Answer: False

For the current day only. The inspection report must be submitted to the vehicle as soon as possible.

Pre-trip

Inspection Report

Date: _____

Vehicle licence plate or unit no.: _____

Semitrailer licence plate or unit no.: _____

ITEMS TO BE CHECKED:

SATISFACTORY

DEFECTIVE

Service brakes	<input type="radio"/>	<input type="radio"/>
Parking brake	<input type="radio"/>	<input type="radio"/>
Steering system	<input type="radio"/>	<input type="radio"/>
Horn	<input type="radio"/>	<input type="radio"/>
Windshield wipers and washer fluid	<input type="radio"/>	<input type="radio"/>
Mirrors	<input type="radio"/>	<input type="radio"/>
Emergency equipment	<input type="radio"/>	<input type="radio"/>
Lights and signals	<input type="radio"/>	<input type="radio"/>
Tires	<input type="radio"/>	<input type="radio"/>
Wheels	<input type="radio"/>	<input type="radio"/>
Suspension	<input type="radio"/>	<input type="radio"/>
Chassis frame	<input type="radio"/>	<input type="radio"/>
Trailer hitch	<input type="radio"/>	<input type="radio"/>
Securing devices	<input type="radio"/>	<input type="radio"/>

No defect found during inspection

Remarks (nature of defect): _____

Name of driver: _____

Driver's signature

Maintenance crew member's signature
(bus, minibus or ambulance)

Operator's or agent's signature, if defects are found

(Duplication authorized)



WHO PERFORMS THE PRE-TRIP INSPECTION?

The pre-trip inspection is conducted by the driver before heading out onto the road. The driver is also responsible for reporting defects discovered during roadside inspections.

Exception

Where **buses, minibuses** and **ambulances** are concerned, the pre-trip inspection may be performed by a maintenance crew member, in which case the latter is considered the person responsible for the inspection and must complete an inspection report, even if the vehicle will be travelling within a 160-km radius of the driver's home base. The original report must be placed in the vehicle and be countersigned by the driver and alternate(s).



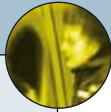

PRE-TRIP INSPECTION PROCEDURE

FOR DRIVERS OPERATING WITHIN A RADIUS OF 160 KM:

within

For the following types of vehicle:

Bus
Minibus
Ambulance
Fire truck¹
Tow truck
Other vehicles subject to inspection (trucks, etc.)

Before starting out, the driver conducts an inspection on his vehicle and completes an inspection report only if he discovers a defect/defects. The inspection report must be kept in the vehicle. Even if the inspection report is not completed, it **must be kept on board at all times** in case a mechanical defect turns up during the trip.

OR

Bus
Minibus
Ambulance
Fire truck¹
Tow truck
Other vehicles subject to inspection (trucks, etc.)

Before starting out, the driver checks the vehicle, completes an inspection report, regardless of whether he finds any defects, and keeps the report in the vehicle.

OR

Bus²⁻³
Minibus²⁻³
Ambulance²⁻³
Fire truck¹⁻³
Tow truck³

Before starting out, the driver checks the vehicle, completes an inspection report for the day (24 hours) and keeps it in the vehicle. Where two or more drivers share the same trip, the report **must be countersigned** by each of the drivers.

OR

Bus²⁻³
Minibus²⁻³
Ambulance²⁻³

The maintenance crew member conducts the check, completes an inspection report for the day (24 hours) **and places it in the vehicle**. The report **must be countersigned** by the initial driver and each of the subsequent drivers, where two or more drivers share the same trip.

¹ See page 7 for the types of fire trucks not subject to pre-trip inspection.

² The 24-hour period does not include Saturdays, Sundays and holidays, provided that the vehicle is not used during that time.

³ Drivers must ensure that a pre-trip inspection was performed on the vehicle no more than 24 hours preceding their departure. Drivers are not required to stop and conduct another check if the 24-hour period expires during the trip.



beyond

FOR DRIVERS OPERATING BEYOND A RADIUS OF 160 KM:

For the following types of vehicle:

- Bus
- Minibus
- Ambulance
- Fire truck¹
- Tow truck
- Other vehicles subject to inspection (trucks, etc.)

Before starting out, the driver checks his vehicle, completes an inspection report, regardless of whether he discovers any defects, and keeps it in the vehicle.

OR

- Bus²⁻³
- Minibus²⁻³
- Ambulance²⁻³
- Fire truck¹⁻³
- Tow truck³

Before starting out, the driver checks his vehicle and completes an inspection report for the day (24 hours). Where two or more drivers share the same trip, the report **must be countersigned** by each of the drivers.

OR

- Bus²⁻³
- Minibus²⁻³
- Ambulance²⁻³

The maintenance crew member conducts the check, completes an inspection report for the day (24 hours) **and places it in the vehicle**. The report **must be countersigned** by the initial driver and each of the subsequent drivers, where two or more drivers share the same trip.

¹ See page 7 for the types of fire trucks not subject to pre-trip inspection.

² The 24-hour period does not include Saturdays, Sundays and holidays, provided that the vehicle is not used during that time.

³ Drivers must ensure that a pre-trip inspection was performed on the vehicle no more than 24 hours preceding their departure. Drivers are not required to stop and conduct another check if the 24-hour period expires during the trip.



WHEN TO CONDUCT THE PRE-TRIP INSPECTION

Drivers must conduct a safety check each work shift (see definition on page 6) before taking to the road. If they must change vehicles or use a new trailer or semitrailer during their shift, they must conduct an inspection before using it.

YOU NEED TO CHANGE SEMITRAILERS DURING A WORK SHIFT. AFTER MAKING THE CHANGE, YOU MUST CONDUCT ANOTHER SAFETY CHECK BEFORE STARTING OUT.

True or False?

Answer: True

SPECIAL PROVISIONS

TRIPS WITH MORE THAN ONE DRIVER

Where two drivers share the same trip, the procedure is as follows:

The first driver conducts a pre-trip check and completes the inspection report. The relief driver conducts an inspection of his own before starting out and fills out another report. The reports are valid for a period not exceeding 24 hours, except if a driver takes 8 consecutive hours or more of rest (new work shift begins), in which case the driver must conduct another check and complete another inspection report.

VEHICLES OPERATED BY MORE THAN ONE DRIVER IN THE SAME WORK SHIFT

If more than one driver uses the same vehicle, each driver must conduct a pre-trip inspection. However, if during the same work shift a driver gets back behind the wheel of a vehicle on which he has already conducted an inspection, he is not required to fill out another pre-departure inspection report, but must have his inspection report in the vehicle. Remember, drivers are responsible for ensuring that their inspection report always reflects the condition of the vehicle at the time they take over behind the wheel. If another driver has used the vehicle, it is always a good idea to conduct your own safety check, or at least read the report filled out by the previous driver, if available, and to update your own report should you discover a defect along the way.



DRIVERS WHO USE THE SLEEPER BERTH

Drivers who divide the compulsory 8 hours of rest into two periods in the sleeper berth must conduct an inspection and fill out an inspection report before starting out on a trip. Thereafter, the driver must make sure an inspection is done and an inspection report filled out within 24 hours prior to starting out every time. Otherwise, he must conduct an inspection and fill out a new report. He may continue in this manner until he takes another 8 consecutive hours of rest or more. At this time he is required to conduct a new inspection and fill out an inspection report.

Drivers who divide the compulsory 8 hours of rest into two periods in the sleeper berth must conduct an inspection before starting out again, and then every 24 hours thereafter until they take at least 8 consecutive hours of rest. Another safety check must be conducted and a new inspection report completed following each 8-hour period of rest.

WORK SHIFTS EXTENDING OVER TWO DAYS

Drivers are not required to conduct another pre-departure inspection just because the date changes (new day) during the same work shift.

A work shift is the period of time during which a driver is on duty. This period is normally preceded and followed by at least 8 consecutive hours of rest. As long as the driver is still on the same shift and does not change vehicles, he is not required to perform another pre-departure safety check.

A WORK SHIFT EXTENDING OVER TWO DAYS

John hits the road at 10:00 Monday night after conducting an inspection. He drives until 2:00 in the morning and then stops for coffee. He is not required to conduct another safety check before starting out again, because even though it is a new day (Tuesday), it is still part of the same shift. John is also continuing the same trip with the same vehicle.

However, John must conduct a new safety check and fill out an inspection report during the day on Tuesday if he rests for 8 consecutive hours or more and then continues driving.



ESTABLISHING A ROUTINE

The point of a pre-departure inspection is to make sure your vehicle is safe to drive. There are various ways to conduct this safety check; it is simply a matter of finding the one that suits you the best and then sticking to it. Establishing a routine saves time while ensuring that you do not forget anything. The procedure proposed below consists in working your way around the vehicle and checking all of the components prescribed by regulation.

If in doubt about the type of defect found (minor or major), consult a mechanic or the vehicle operator.

Routine inspection procedure (combination of vehicles)

- Service brakes
- Parking brake
- Steering
- Horn
- Windshield wipers and washer
- Mirrors
- Emergency equipment
(flares or reflectors)
- Lights and signals
- Tires
- Wheels
- Suspension
- Chassis frame
- Trailer hitch (coupling device)
- Securing devices

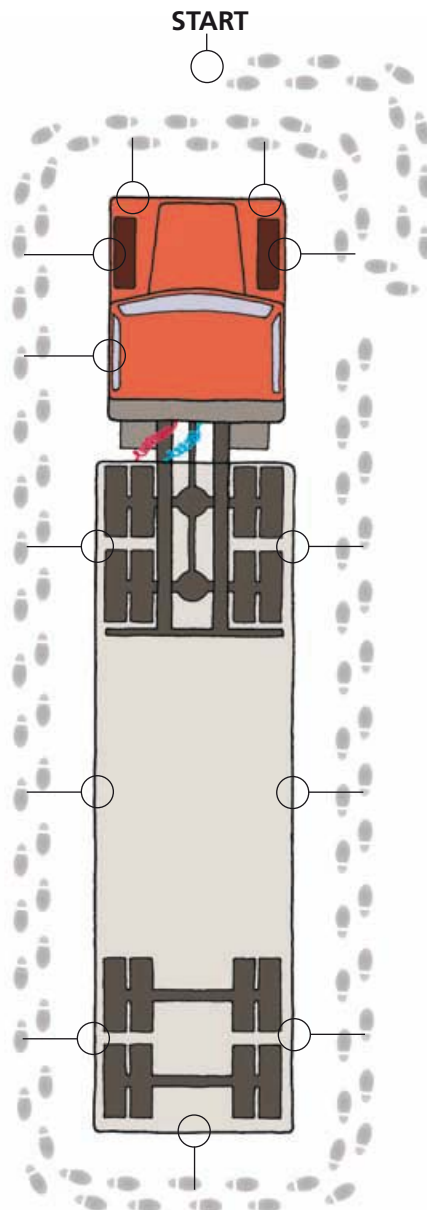



Routine inspection procedure (motor coach)

- Service brakes
- Parking brake
- Steering
- Horn
- Windshield wipers and washer
- Mirrors
- Emergency equipment (flares or reflectors)
- Lights and signals
- Tires
- Wheels
- Suspension

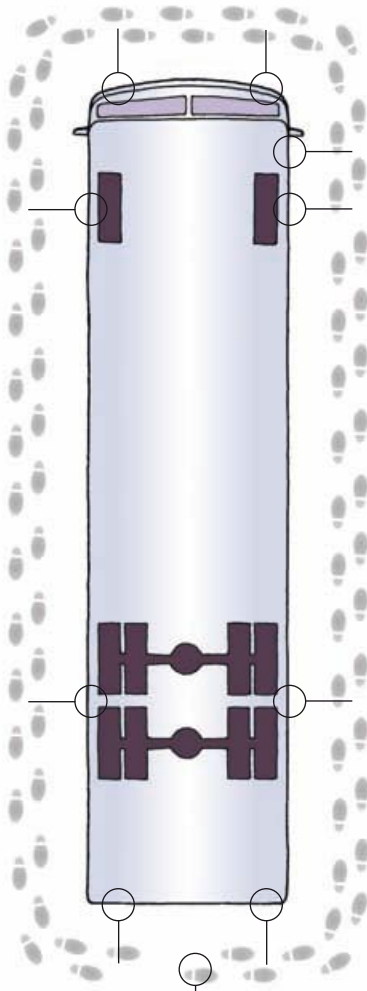

Routine inspection procedure (school bus)

- Service brakes
- Parking brake
- Steering
- Horn
- Windshield wipers and washer
- Mirrors
- Emergency equipment (reflectors, chemical fire extinguisher, first-aid kit)
- Lights and signals (flashing lights, stop sign, alternate flashing lights)
- Tires
- Wheels
- Suspension
- Chassis frame

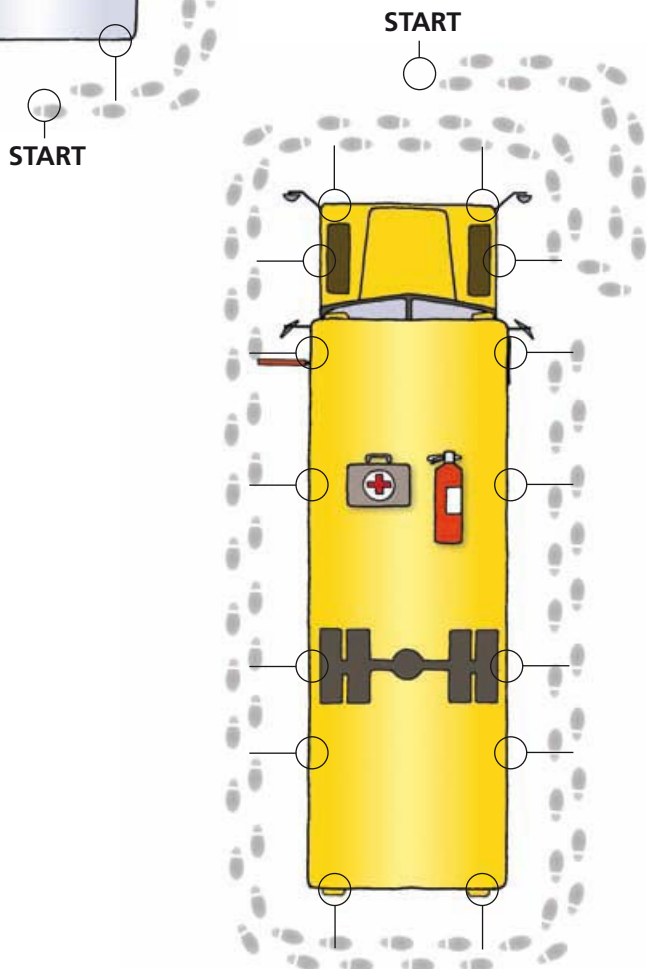



OBLIGATIONS OF HEAVY VEHICLE OWNERS AND OPERATORS

Obligations

Operators must:

- Ensure that drivers or maintenance crew members conduct the pre-departure safety check of the heavy vehicle under the operator's responsibility;
- Place an inspection report in each heavy vehicle for which they are responsible;
- Ensure that their drivers record all of the information prescribed by regulation in the inspection report;
- Ensure that their drivers keep the inspection report in the vehicle;
- Sign the inspection report where a defect is recorded;
- Where the operator is not the owner of the heavy vehicle, inform the owner without delay of any defect discovered and forward a copy of the heavy vehicle's inspection report to the owner;
- In the case of a minor defect, make the necessary repairs or have them made within 48 hours to preserve the right to maintain the vehicle in operation;
- In the case of a major defect, not operate the vehicle or allow it to be operated until the defect has been repaired;
- Maintain the pre-departure inspection reports for a period of 12 months.

Owners (even if they are not the operator of the heavy vehicle) must:

- Maintain their heavy vehicles in good mechanical condition;
- In the case of a minor defect, make the necessary repairs or have them made within 48 hours to preserve the right to maintain the vehicle in operation;
- In the case of a major defect, not operate the vehicle or allow it to be operated until the defect has been repaired;
- Obtain a copy of the inspection report from the operator;
- Correct any minor defect reported to them;
- Correct any major defect reported to them;
- Maintain the pre-departure inspection reports and proof of repairs for a period of 12 months.

Section of HSC*	Fine
519.15	\$700 to \$2,100
519.16	\$700 to \$2,100
519.16	\$350 to \$1,050
519.16	\$350 to \$1,050
519.16	\$350 to \$1,050
519.16	\$700 to \$2,100
519.47	\$350 to \$1,050
519.47	\$700 to \$2,100
519.20	\$700 to \$2,100
519.15	\$700 to \$2,100
519.17	\$350 to \$1,050
519.17	\$700 to \$2,100
519.18	\$700 to \$2,100
519.17	\$350 to \$1,050
519.17	\$700 to \$2,100
519.20	\$700 to \$2,100

* HSC: Highway Safety Code



Obligations

Drivers must:

- Conduct a pre-trip safety check on the vehicle they are driving;
- Complete the inspection report;
- Update the inspection report;
- Keep the inspection report in the vehicle at all times;
- Not have in their possession more than one inspection report for the vehicle they are driving;
- Submit the inspection report to a peace officer upon request;
- Immediately report a minor defect to the vehicle owner or operator;
- Immediately report a major defect to the vehicle owner or operator;
- Not drive a motor vehicle that has a major defect discovered during a pre-departure safety check.

OBLIGATIONS OF HEAVY VEHICLE DRIVERS

Section of HSC*	Fine
519.2	\$350 to \$1,050
519.3	\$350 to \$1,050
519.3	\$175 to \$525
519.4	\$350 to \$1,050
519.4	\$350 to \$1,050
519.4	\$350 to \$1,050
519.5	\$175 to \$525
519.5	\$350 to \$1,050
519.6	\$350 to \$1,050

* HSC: Highway Safety Code

Components and systems subject to inspection



COMPONENTS AND SYSTEMS SUBJECT TO INSPECTION

This chapter discusses the vehicle components and systems drivers are required to inspect during the pre-departure inspection. The following pages indicate the components to be checked, their location and the inspection procedure. This approach will enable you to differentiate between minor and major defects.



Indicates a minor defect



Indicates a major defect



Indicates an offence under Québec's Highway Safety Code

Service Brakes

Service brakes – Air brake system

If the vehicle has air brakes, make sure that air is circulating freely through the main lines to ensure a more thorough inspection. For air spring suspension systems, open the suspension line.

INSPECTION PROCEDURE

OBSERVABLE DEFECT CATEGORY

1.1 CHECK TO SEE AT WHAT PRESSURE LEVEL THE COMPRESSOR STOPS OPERATING

Component: air compressor governor¹

From the driver's seat

- Keep engine running at about 1000 rpm and check governor cut-out pressure;
- Note pressure gauge reading when pressure stops rising.



Minor defect if governor cut-out pressure is not between 805 kPa (117 psi) and 945 kPa (137 psi).

¹ Pressure is expressed in international units in kilopascals (kPa). The kPa is calculated by multiplying the psi by 6.895.

1.2 CHECK AIR PRESSURE REQUIRED TO APPLY SERVICE BRAKES COMPLETELY

Components: compressed air reservoirs

From the driver's seat

- Release parking brake¹;
- Keep engine running at about 1000 rpm until air pressure level stops rising;
- Turn off engine²;
- Fully apply brake pedal;
- Check pressure gauge and note pressure drop and compare with the table on the right.

¹ When checking the air brake system operation, you should always release the parking brake.

² Do not turn the engine off if the compressor begins operating when you apply the brake pedal.

Type of vehicle



Minor defect if pressure drop exceeds:

- | | | |
|-----------------------|---|------------------|
| • Bus | } | 130 kPa (19 psi) |
| • Straight truck | | |
| • Road tractor | | |
| • Tractor-semitrailer | | 20% of pressure |
| • Truck-trailer | | 20% of pressure |
| • Double road train | | 20% of pressure |

*Faulty brakes are the most common defect and the leading cause of accidents among heavy vehicles.**

* Gou, Michel (1997). *Résumé de l'étude sur l'incidence de l'état mécanique des poids lourds sur la sécurité routière*. École Polytechnique, Montréal, 1997, p. XIV

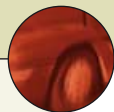

INSPECTION PROCEDURE

OBSERVABLE DEFECT CATEGORY

1.3 CHECK BRAKING SYSTEM FOR LEAKS

Component: air brake system

From the driver's seat

- Release parking brake¹;
- Keep engine running at about 1000 rpm until air pressure level stops rising;
- Turn off engine²;
- Fully apply brake pedal;
- Check pressure gauge. If the needle indicates a continuous drop in pressure, apply brake pedal for at least one minute. Determine the drop in air pressure using table on the right.

¹ Always release the parking brake when checking for leaks in the braking system so that all air brake lines fill.
² Do not turn the engine off if the compressor begins operating when you apply the brake pedal.

Type of vehicle

Minor (a) or **major (b)** defect if pressure loss in one minute exceeds:

Bus	}		a. 20 kPa (3 psi)	
Straight truck				b. 40 kPa (6 psi)
Road tractor				
Tractor-semitrailer	}		a. 28 kPa (4 psi)	
Truck-trailer				b. 48 kPa (7 psi)
Double road train	}			a. 35 kPa (5 psi)
				b. 62 kPa (9 psi)

1.4 CHECK GOVERNOR CUT-IN PRESSURE

Component: air compressor governor

From the driver's seat

- Release parking brake¹;
- With engine idling, check pressure gauge then pump brake pedal until pressure drops to 550 kPa (80 psi)²;
- Keep your eyes on the pressure gauge without touching brake pedal.

¹ When checking the service brakes in a vehicle with an air brake system, you should release the parking brake unless the vehicle is equipped with an anti-brake compounding device. Otherwise, you could damage the brake cylinders.
² Pumping can be stopped when the compressor cuts in, with pressure above 550 kPa (80 psi).

Minor defect if governor cut-in pressure is below 550 kPa (80 psi).



Mandatory inspection

- Drivers must pull over in brake testing areas and check their brakes when they see this sign.



INSPECTION PROCEDURE

OBSERVABLE DEFECT CATEGORY

1.5 CHECK LOW AIR PRESSURE WARNING FOR SERVICE BRAKES

Component: low air pressure indicator (warning light, buzzer or both)

From the driver's seat

- Turn the switch to the "ON" position or, if the pressure is below 380 kPa (55 psi), turn on the ignition to bring the pressure up;
- Release parking brake¹;
- Keep your eye on the low pressure gauge and pump the brake pedal until the pressure in the system drops below 380 kPa (55 psi);
- Check to see if the low pressure warning light or buzzer comes on or sounds.



Minor defect if buzzer cannot be heard or warning light does not come on when air pressure in the braking system is less than 380 kPa (55 psi).

¹ When checking the service brakes in a vehicle with an air brake system, you should release the parking brake unless the vehicle is equipped with an anti-compound device. Otherwise, you could damage the brake cylinders.

1.6 CHECK COMPRESSOR OUTPUT FOR SERVICE BRAKES TO BE EFFECTIVE

Component: compressor

From the driver's seat

- Release parking brake¹;
- With the engine idling, check the pressure gauge; if pressure is above 620 kPa (90 psi), pump brake pedal until pressure drops to slightly below 620 kPa (90 psi);
- With your eyes still on the pressure gauge, depress the brake pedal as far as it will go and hold it there.



Major defect if compressor does not reach or maintain a minimum pressure of 620 kPa (90 psi) in braking system.

¹ Always release the parking brake when checking compressor performance to ensure that air circulates freely through the brake lines.

Service brakes – Hydraulic braking system

INSPECTION PROCEDURE

1.7 CHECK SERVICE BRAKE FLUID LEVEL

In engine compartment

- Check fluid level in master cylinder reservoir. If you need to open the master cylinder reservoir to check the fluid level, we recommend that you take certain precautions. First of all, clean all around the reservoir opening so that the fluid will not be contaminated by foreign objects or substances. Also, put the seal back properly if it was moved, then close the lid carefully.

OBSERVABLE DEFECT CATEGORY

Component: master cylinder reservoir



Major defect if brake fluid level in master cylinder reservoir is lower than one quarter of the maximum level.



Minor defect if level of brake fluid in master cylinder reservoir is below the level specified by the manufacturer or, where no level is specified, is more than 10 mm (3/8 in) below the neck of the filler opening.

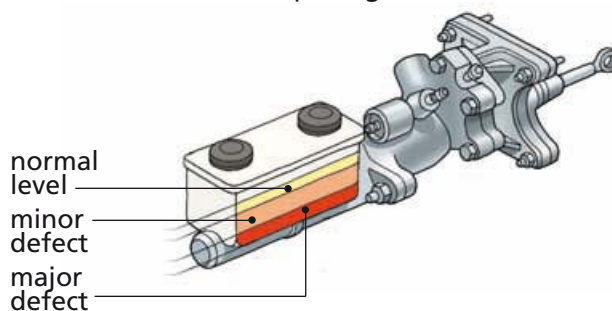

1.8 CHECK POWER BRAKES¹

From the driver's seat, in the case of a vacuum brake booster

- Turn engine off;
- Pump brake pedal several times;
- Depress brake pedal again with average amount of force;
- Turn engine on;
- Check pedal movement.

OR

From the driver's seat, in the case of hydraulic power brakes

- Turn engine off;
- Depress brake pedal with average amount of force;
- Listen for the electric pump sound.



Major defect if brake pedal does not drop slightly after turning on engine.



Major defect if electric pump does not function when engine is turned off.

¹ Power brakes on an air brake system cannot be checked using either of these methods.



INSPECTION PROCEDURE

OBSERVABLE DEFECT CATEGORY

1.9 CHECK TO SEE IF SERVICE BRAKE INDICATOR LIGHT IS WORKING PROPERLY

Component: brake system warning light

From the driver's seat

- Release parking brake¹;
- Turn ignition switch to the "ON" position;
- Check indicator light;
- Start the engine;
- Check indicator light again.

¹ Necessary only if the service and parking brake share the same warning light.



Minor defect if:

- The light does not come on when the ignition switch is turned to the "ON" position;
- The light stays on once the engine has started.

1.10 CHECK BRAKING SYSTEM FOR LEAKS AND CHECK PRESSURE

Component: brake system

From the driver's seat

- With the engine running,¹ press down hard² on the brake pedal for at least 10 seconds;
- At the same time, observe pedal movement.

¹ With hydraulic power brakes, the engine need not be running.

² If you have hydraulic power brakes, much less pressure on the brake pedal is required than with a compressed air or vacuum brake booster.



Major defect if:



- The pedal has to be depressed several times in order to pressurize the circuit (pedal resistance);
- The brake pedal reaches the floor in less than 10 seconds.



Minor defect if brake pedal reaches the floor in 10 seconds or more.



Parking brake

INSPECTION PROCEDURE	OBSERVABLE DEFECT CATEGORY
2.1 CHECK HOW EFFECTIVE PARKING BRAKE IS Component: parking brake	
<p><u>Inspections done completely from the driver's seat, with the engine running</u></p> <ul style="list-style-type: none"> Fully apply parking brake¹; Gently attempt to drive the vehicle forward². <p>¹ In the case of a tractor-trailer, tractor-semitrailer or double road train, the parking brakes have to be applied on both the tractor and the trailer.</p> <p>² If your vehicle has a standard transmission, you need to be especially cautious and use the highest gear that allows you to move ahead.</p>	<p> Minor defect if parking brake fails to hold vehicle.</p>
2.2 CHECK PARKING BRAKE RELEASE Component: parking brake	
<ul style="list-style-type: none"> Release parking brake; Slowly drive a few metres forward, watching wheel rotation in rearview mirrors¹; Stop vehicle. <p>¹ With a combination vehicle, it may be necessary to swerve from left to right so as to check on wheel movement of the rear unit.</p>	<p> Minor defect if brake does not move completely away from wheel when released.</p>
2.3 CHECK WORKING ORDER OF PARKING BRAKE LIGHT Component: parking brake light	
<p>With a hydraulic brake system, the following checks are required in addition to the above inspections:</p> <ul style="list-style-type: none"> Apply parking brake; Check parking brake light; Release parking brake; Check parking brake light again. 	<p> Minor defect if:</p> <ul style="list-style-type: none"> the light does not come on when the parking brake is applied; the light stays on after the parking brake is released. <div style="background-color: #d9ead3; padding: 10px; margin-top: 20px;"> <p>THE PARKING BRAKE DOES NOT PREVENT THE VEHICLE FROM MOVING. IS THIS A MAJOR OR A MINOR DEFECT?</p> <p style="text-align: right;">Answer: Minor defect</p> </div>

Steering System



INSPECTION PROCEDURE

OBSERVABLE DEFECT CATEGORY

3.1 CHECK POWER STEERING FLUID LEVEL

Component: power steering reservoir

In engine compartment

- Check power steering fluid level in reservoir. If you need to open the power steering reservoir to check the fluid level, we recommend that you take certain precautions. First of all, clean all around the reservoir opening so that the fluid will not be contaminated by foreign objects or substances. Also, put the seal back properly if it was moved, then close the lid carefully.



Minor defect if fluid is below the level specified by the manufacturer.

3.2 CHECK CONDITION OF POWER STEERING BELT

Component: power steering belt

In engine compartment

- Examine power steering belt.



Minor defect if belt has a cut in it.

INSPECTION PROCEDURE

OBSERVABLE DEFECT CATEGORY

3.3 CHECK TO SEE IF STEERING COLUMN IS FIRMLY ANCHORED AND CHECK STEERING WHEEL FOR PLAY

Components: anchorages at top of steering column and steering wheel

From the driver's seat

- Make sure steering wheel is locked (if it tilts or is telescopic) in the proper driving position;
- Try to move steering wheel:
 - up and down;
 - from left to right and back;
 - towards you then back towards the dash.



Major defect if:

- The column is in danger of coming loose from its anchorages;
- The steering wheel is in danger of breaking away from the column.



Minor defect if:

- The column moves out of its normal position;
- The steering wheel does not remain locked in place.

3.4 CHECK OPERATION OF POWER STEERING

Component: power steering

From the driver's seat

- With the engine running, turn the steering wheel one way then the other so that your wheels move.



Major defect if power steering does not function at all.

*After brakes, defects in the tires, chassis frame, lights and signals, and steering system are the leading cause of heavy vehicle accidents.**

THE STEERING WHEEL IS IN DANGER OF SEPARATING FROM THE STEERING COLUMN. IS THIS A MAJOR OR A MINOR DEFECT?

Answer: Major defect

* Gou, Michel (1997). *Résumé de l'étude sur l'incidence de l'état mécanique des poids lourds sur la sécurité routière*. École Polytechnique, Montréal, 1997, p. XIV

Horn

INSPECTION PROCEDURE

OBSERVABLE DEFECT CATEGORY

4.1 CHECK HORN OPERATION

Component: horn

From the driver's seat

- Honk the horn.





Minor defect if horn does not function properly.

If a vehicle has two horns, the driver must check that at least one of them is in working order.

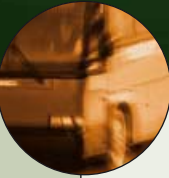
Windshield Wipers and Washer



INSPECTION PROCEDURE	OBSERVABLE DEFECT CATEGORY
5.1 CHECK OPERATION OF WINDSHIELD WIPERS Component: windshield wipers	
<p><u>From the driver's seat</u></p> <ul style="list-style-type: none"> • Switch on your wipers; • Check to see how efficiently they work by placing the function lever in each of the operating positions. 	<ul style="list-style-type: none">  Major defect¹ if the windshield wiper on the driver's side: <ul style="list-style-type: none"> • Is missing; • Does not work; • Wipes the windshield poorly.  Minor defect¹ if: <ul style="list-style-type: none"> • The wiper on the passenger's side is missing; • The wiper on the passenger's side does not work; • The wiper on the passenger's side wipes the windshield poorly; • One of the wipers is worn or poorly adjusted. <p><small>¹ These defects must be taken into consideration at all times, and not just when the weather is poor.</small></p>
5.2 CHECK WASHER FLUID Component: windshield washer fluid	
<p><u>From the driver's seat</u></p> <ul style="list-style-type: none"> • Activate the washer lever; • Check to see if the washer fluid sprays the windshield. 	<ul style="list-style-type: none">  Minor defect if: <ul style="list-style-type: none"> • The washer fluid does not spray the windshield; • The washer fluid does not wash the windshield properly.

**THE WINDSHIELD WIPER ON THE DRIVER'S SIDE IS MISSING.
IS THIS A MAJOR OR A MINOR DEFECT?**

Answer: Major defect

Outside Mirrors

INSPECTION PROCEDURE

6.1 CHECK TO MAKE SURE REARVIEW MIRRORS ARE CLEAR

From inside and outside the cab

- Look in mirrors.

6.2 CHECK TO MAKE SURE REARVIEW MIRRORS ARE SOLIDLY MOUNTED

Outside the cab

- Carefully try to move mirrors to make sure they are properly anchored;
- Carefully try to move mirror supports and anchorages to make sure they are solidly attached to the vehicle.

In the case of school buses, the mirror on the front of the vehicle must also be checked.

OBSERVABLE DEFECT CATEGORY

Components: outside rearview mirrors



Minor defect if a mirror is missing, broken, cracked, tarnished or dull.

Components: mirror anchorages



Minor defect if:



- a rearview mirror is not well anchored;
- a rearview mirror does not stay in position once adjusted.

A REARVIEW MIRROR IS BROKEN.
IS THIS A MAJOR OR A MINOR DEFECT?

Answer: Minor defect



Emergency Equipment

INSPECTION PROCEDURE	OBSERVABLE DEFECT CATEGORY
7.1 CHECK MANDATORY EMERGENCY EQUIPMENT	
<p><u>Inside cab or vehicle's load space</u></p> <ul style="list-style-type: none"> Check to see if there are any flares or reflectors in the vehicle. In the case of vehicles (other than school buses) used for the transportation of school children, reflectors are mandatory. 	<p>Components: flares and reflectors¹</p> <p> It is an offence if the vehicle is not equipped with at least three reflectors or flares. This is an offence under section 225 of the Highway Safety Code. The driver is liable to a fine of \$90 to \$270.</p>
7.2 CHECK SCHOOL BUS EMERGENCY EQUIPMENT	
<p><u>Inside bus</u></p> <ul style="list-style-type: none"> Check to see if there is a fire extinguisher and a first-aid kit in the bus. 	<p>Components: chemical fire extinguisher and first-aid kit</p> <p> It is an offence if the school bus does not have a fire extinguisher or a first-aid kit. This is an offence under section 44 of the Regulation respecting road vehicles used for the transportation of school children. The driver is liable to a fine of \$125 to \$375.</p>
7.3 CHECK THAT FIRE EXTINGUISHER AND FIRST-AID KIT ARE PROPERLY MOUNTED OR ANCHORED	
<p><u>Inside bus</u></p> <ul style="list-style-type: none"> Check supports and mountings for fire extinguisher and first-aid kit. 	<p>Components: fire extinguisher and first-aid kit supports and mountings</p> <p> Minor defect if either extinguisher or first-aid kit, or both of them, is not properly mounted or anchored.</p>

**THERE IS NO EMERGENCY EQUIPMENT IN A SCHOOL BUS.
IS THIS A MAJOR OR A MINOR DEFECT?**

Answer: Neither
This is not a defect, but rather an offence under the Highway Safety Code.

Lights and Signals

Lights and signals subject to pre-departure inspection:

1. Headlights
2. Front parking lights¹
3. Rear parking lights
4. Front turn-signal lights
5. Rear turn-signal lights
6. Front hazard warning lights
7. Rear hazard warning lights

¹ Mandatory on vehicles 2.03 m or less wide

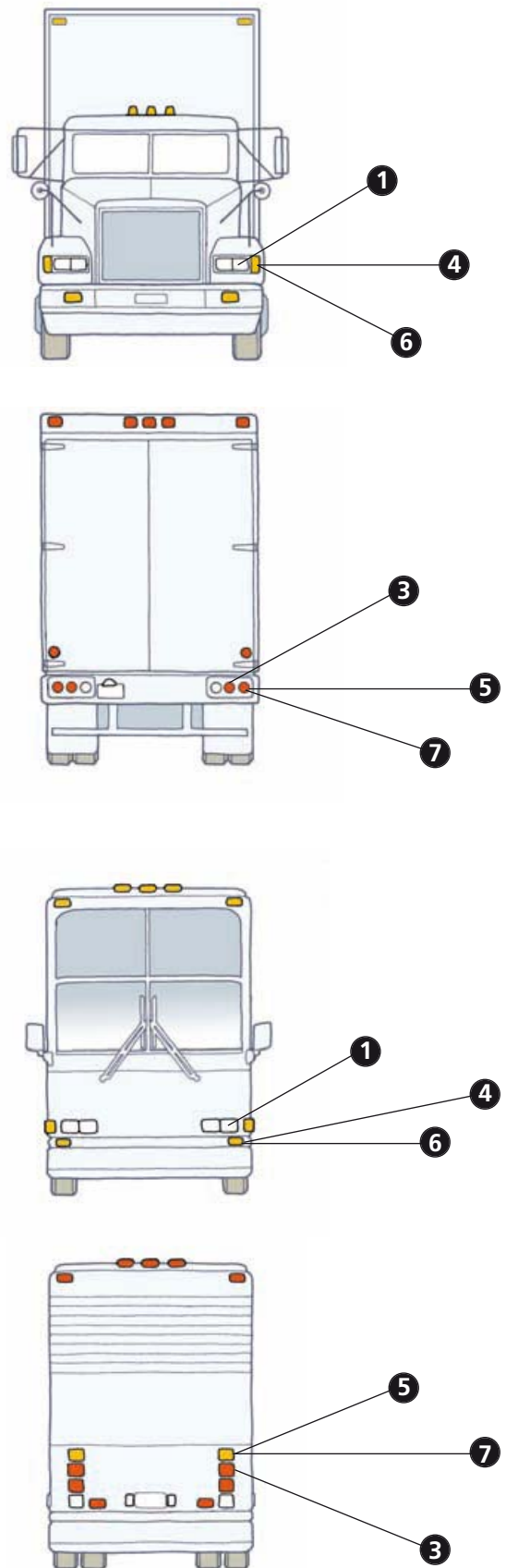



1. Headlights
2. Front parking lights¹
3. Rear parking lights
4. Front turn-signal lights
5. Rear turn-signal lights
6. Front hazard warning lights
7. Rear hazard warning lights
8. Flashing lights on front of bus
9. Flashing lights at rear of bus
10. Alternate flashing lights on stop sign

¹ Mandatory on vehicles 2.03 m or less wide

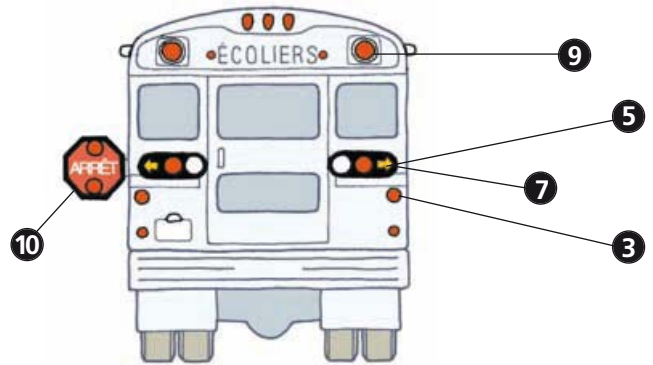
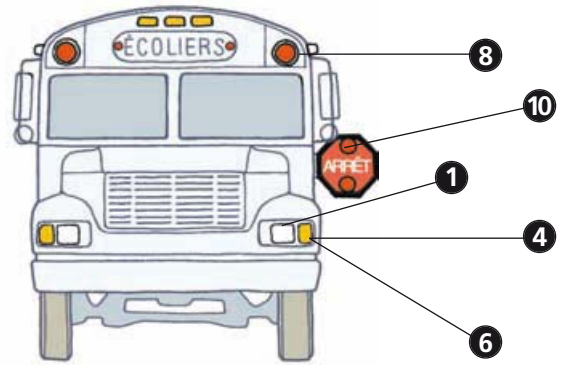

1. Headlights
2. Front parking lights¹
3. Rear parking lights
4. Front turn-signal lights
5. Rear turn-signal lights
6. Front hazard warning lights
7. Rear hazard warning lights

¹ Mandatory on vehicles 2.03 m or less wide

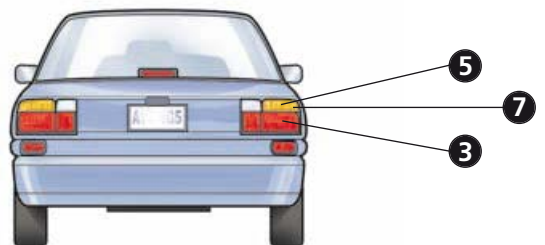
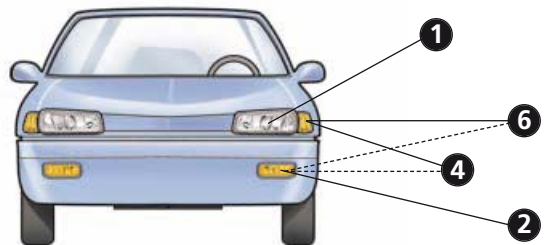



All vehicles

On a vehicle combination, the rear lights that must be checked are those on the furthest unit.

INSPECTION PROCEDURE

OBSERVABLE DEFECT CATEGORY

8.1 CHECK TURN SIGNALS

Components: turn-signal lights

From the driver's seat

- Turn on left and right turn signals.

Outside vehicle

- Check to make sure all turn-signal lights are working: front right and left, and rear right and left.



Minor defect if a light does not flash when the corresponding turn signal is turned on.

8.2 CHECK HAZARD WARNING LIGHTS (EMERGENCY FLASHERS)

Components: hazard warning lights

From the driver's seat

- Turn on hazard warning switch.

Outside vehicle

- Check to make sure hazard warning lights are working: front right and left, and rear right and left.



Minor defect if a flasher does not work when switched on.

8.3 CHECK PARKING LIGHTS

Components: rear parking lights

From the driver's seat

- Turn on parking light switch.

Outside vehicle

- Check to make sure right and left front and rear parking lights are working;

Parking lights are mandatory in front only for vehicles 2.03 m or less in width. Regardless of vehicle width, the operation of any parking lights must be checked.



Major defect¹ if the vehicle does not have at least one rear parking light that works.¹



Minor defect¹ if:

- One of the rear parking lights does not work when switched on¹;
- One or both of the front parking lights does not work when switched on.

¹ These defects must be taken into consideration at all times, and not only at night.

THE VEHICLE DOES NOT HAVE AT LEAST ONE REAR PARKING LIGHT THAT WORKS. THIS A MAJOR OR A MINOR DEFECT?

Answer: Major defect



INSPECTION PROCEDURE

8.4 CHECK LOW-BEAM HEADLIGHTS

From the driver's seat

- Turn on headlight switch.

Outside vehicle

- Check right and left headlights (low beam).

With school buses, you need to check the following items in addition to those already covered:

School buses

INSPECTION PROCEDURE

8.5 CHECK FLASHING LIGHTS

From the driver's seat

- Turn on flashing lights.

Outside the bus

- Check flashing lights on the right and left, in front and in back.

OBSERVABLE DEFECT CATEGORY

Components: low-beam headlights



Major defect¹ if the vehicle does not have at least one low-beam headlight that works.¹



Minor defect¹ if one of the low-beam headlights does not work when switched on.

¹ These defects must be taken into consideration at all times, and not only at night.

OBSERVABLE DEFECT CATEGORY

Components: flashing lights



Minor defect if one of the flashing lights does not work.



HOWEVER, CARRYING SCHOOLCHILDREN IS PROHIBITED IF THE FLASHING LIGHTS ARE NOT WORKING.

This is an offence under section 229 of the Highway Safety Code. The driver is liable to a fine of \$350 to \$1,050.



INSPECTION PROCEDURE

OBSERVABLE DEFECT CATEGORY

8.6 CHECK STOP SIGN OPERATION

Component: stop sign

From the driver's seat

- Operate the stop sign arm;
- Check the stop sign.



Minor defect if stop sign does not extend at a right angle to the bus when operated.



HOWEVER, CARRYING SCHOOLCHILDREN IS PROHIBITED IF THE STOP SIGN IS NOT WORKING.

This is an offence under section 229 of the Highway Safety Code. The driver is liable to a fine of \$350 to \$1,050.

8.7 CHECK ALTERNATE FLASHING LIGHTS

Components: alternate flashing lights on stop sign

From the driver's seat

- Operate the stop sign arm;
- Check flashing lights at the top and bottom of the stop sign.



Minor defect if one of the alternate flashing lights does not work when the stop sign is at a right angle to the bus.



HOWEVER, CARRYING SCHOOLCHILDREN IS PROHIBITED IF THE ALTERNATE FLASHING LIGHTS ARE NOT WORKING.

This is an offence under section 229 of the Highway Safety Code. The driver is liable to a fine of \$350 to \$1,050.



Tires

Only tires on weight-bearing axles must be checked.

INSPECTION PROCEDURE

OBSERVABLE DEFECT CATEGORY

9.1 CHECK TIRE CONDITION

Components: tires

Around vehicle

- Inspect all visible parts of tires.

N.B. If you are in doubt as to whether a tire has lost air, use a pressure gauge.



Major defect if:

- A single tire or one of dual tires in the same wheel assembly is deflated or has an audible air leak;
- A single tire has foreign material embedded in the tread or sidewall that could cause a puncture;
- A tire touches a fixed part of the vehicle or the other tire on a dual wheel assembly;
- A single tire or both tires on a dual wheel assembly is/are so cut or worn that the rib or steel belt is exposed, or is/are bulged due to a defect in the carcass.

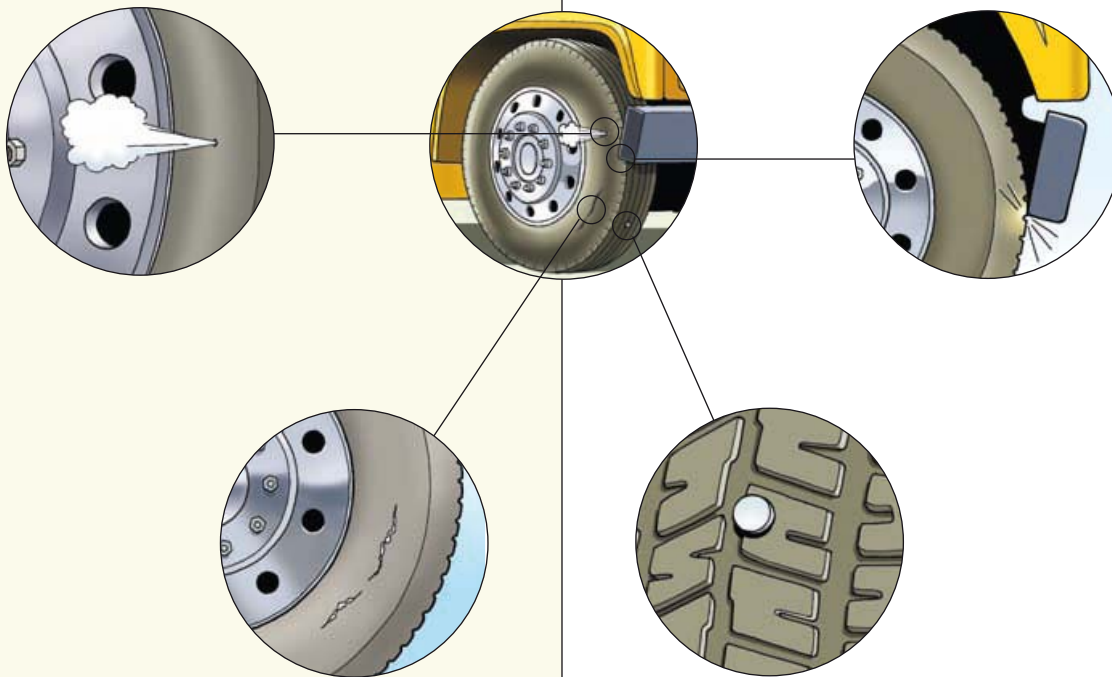

INSPECTION PROCEDURE
(CONT'D)

9.1 CHECK TIRE CONDITION

OBSERVABLE DEFECT CATEGORY
(CONT'D)

Components: tires



Minor defect if:

- A wear indicator comes in contact with the road;
- The tread or rubber compound of the sidewall is separated from the carcass of the tire;¹
- The tire valve is worn down, damaged, scraped or gashed;
- Foreign material is embedded in the tread or sidewall of a dual tire and could cause a flat;
- One of the tires on a dual wheel assembly is cracked or so cut or worn that the rib or steel belt is exposed;
- One of the tires on a dual wheel assembly is abnormally bulged or misshapen.

¹ In the case of retreads, a separation 6 mm (1/4 in.) wide or less is considered normal.

A TIRE NEEDS AIR OR HAS AN AUDIBLE AIR LEAK.

IS THIS A MAJOR OR A MINOR DEFECT?

Answer: Major defect



Wheels

Only wheels on weight-bearing axles must be checked.

INSPECTION PROCEDURE

OBSERVABLE DEFECT CATEGORY

10.1 CHECK WHEEL CONDITION

Components: wheels

Around vehicle

- Check visible parts of all wheels, paying special attention to spokes, rims and discs.



Major defect if:

- A wheel is broken or cracked or has been welded;
- A stud hole is stretched into an oval shape or stretched in any other way.

10.2 CHECK LUGS AND WHEEL RETAINERS

Components: lugs and wheel retainers (nuts, bolts and wheel rim clamps)

Around vehicle

- Inspect lugs and wheel retainers.



Major defect if a lug nut or wheel retainer is missing, cracked, broken or loose.

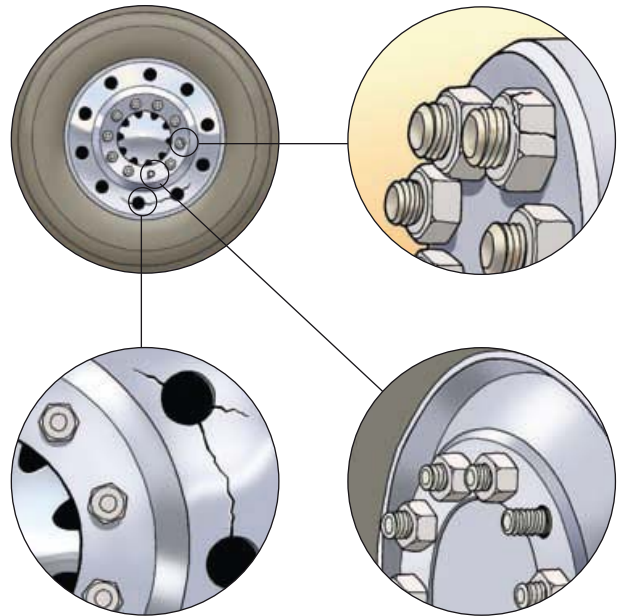

**ONE OF THE FRONT WHEELS ON A HEAVY VEHICLE IS BROKEN.
IS THIS A MAJOR OR A MINOR DEFECT?**

Answer: Major defect

10.3 CHECK SPARE WHEEL CONDITION AND CARRIER

Components: spare wheel, carrier and spare wheel anchorage

Behind cab or under vehicle

- Visually inspect spare wheels, including the tires, and carriers, retainers and anchorages for each.



Minor defect if:

- The spare wheel is not in good enough condition to use on the road;
- The anchorage or carrier does not hold the spare wheel firmly against the vehicle.

Suspension

Only the suspension on weight-bearing axles must be checked.

Metal spring suspension

INSPECTION PROCEDURE

11.1 CHECK POSITION OF SUSPENSION COMPONENTS AND PARTS

Around vehicle

- Position yourself so that you can check as many metal spring suspension components as possible to make sure that none are missing, loose, cracked, broken or damaged. (Leaf spring suspension, for instance, includes many parts, such as the master leaf, leaves, spring bracket, shackle, U-bolt, rubber pad, etc.).

OBSERVABLE DEFECT CATEGORY

Components: axle and wheel anchorages and fasteners



Major defect if:

- The wheels are not parallel;
- An axle or wheel has moved out of its normal position;
- A leaf or coil spring is so out of place that it touches a rotating component.

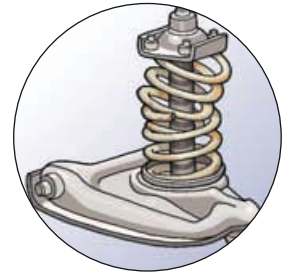

11.2 CHECK CONDITION OF LEAF SPRINGS

Around vehicle

- Visually inspect leaves.



Major defect if:

- A master leaf is broken;
- 25% or more of the leaf springs of an assembly are broken or missing.

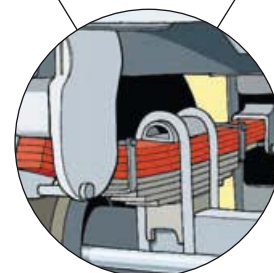
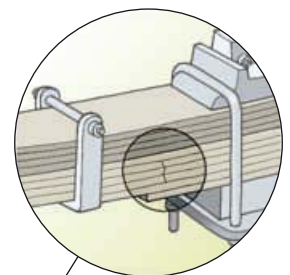
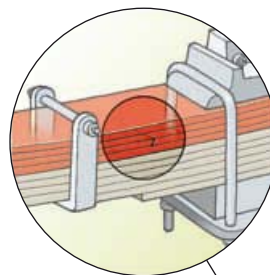



Air spring suspension

In the case of an air suspension, the person who does the safety check must make sure that compressed air is circulating in the suspension lines. If the air pressure gauge reading is under 450 kPa (65 psi), turn on the engine in order to load the suspension lines before doing the check.

INSPECTION PROCEDURE

11.3 CHECK LEVEL OF VEHICLE

Around vehicle

- Look at vehicle to see if it is level. If it leans to one side, check the air springs to make sure they are properly inflated. (It may be necessary to start the engine so as to determine if the air leak is a minor or a major defect);
- Listen for noises from the suspension supply lines.

OBSERVABLE DEFECT CATEGORY

Components: air springs and air supply system



Major defect if an air leak in the air suspension lines cannot be compensated by the compressor when the engine is idling.



Minor defect if there is an air leak in the suspension air supply system.

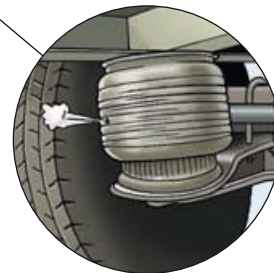
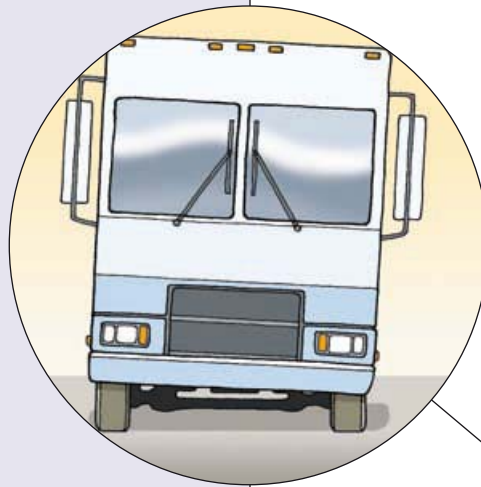



INSPECTION PROCEDURE

OBSERVABLE DEFECT CATEGORY

11.4 CHECK POSITION OF SUSPENSION COMPONENTS AND PARTS

Components: axle anchorages and parts

Around vehicle

- Position yourself so that you can check as many air suspension components as possible to make sure that none are missing, loose, cracked, broken or damaged. (This kind of suspension includes many parts, such as the spring, supports, etc.).



Major defect if:

- The wheels are not parallel;
- An axle or wheel has moved out of its normal position.

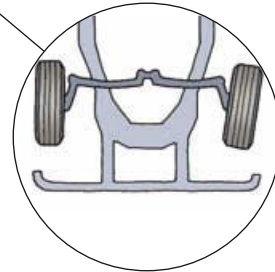
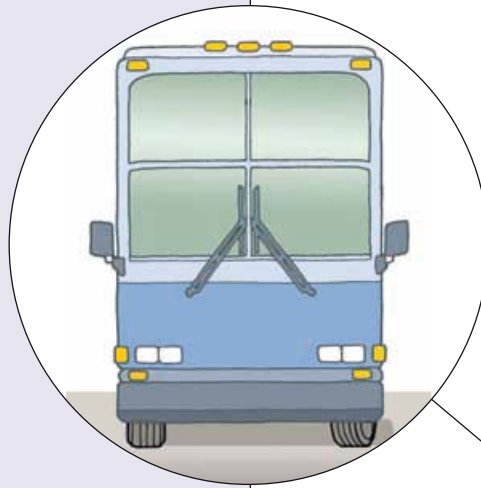

Chassis Frame

INSPECTION PROCEDURE

12.1 CHECK CONDITION OF SIDE RAILS AND CROSSMEMBERS

Around vehicle

- Inspect all visible parts of side rails and crossmembers.

A CROSSMEMBER OF THE CHASSIS FRAME IS BROKEN SUCH THAT IT COMES IN CONTACT WITH A MOVING PART OR WITH THE VEHICLE BODY.

IS THIS A MAJOR OR A MINOR DEFECT?

Answer: Major defect

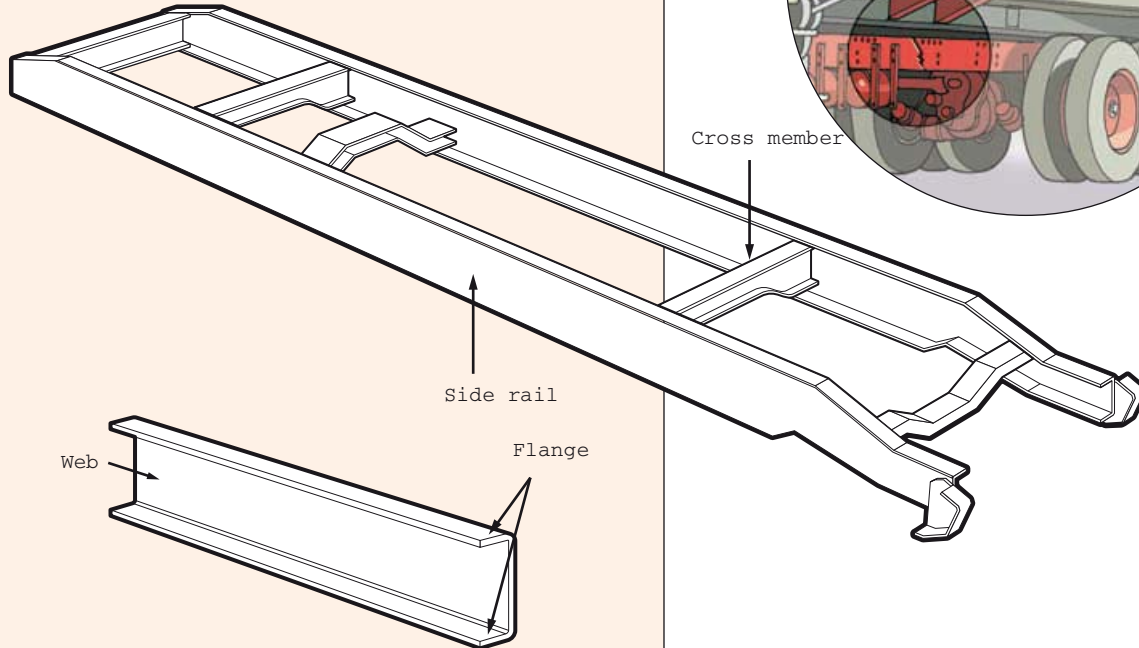

OBSERVABLE DEFECT CATEGORY

Components: chassis frame side rails and crossmembers



Major defect if any of the side rails is in danger of breaking.



Minor defect if:

- The side rail web is cracked;
- The side rail flange is cracked;
- Crossmember is cracked.

12.2 CHECK STRENGTH OF CHASSIS FRAME

Around vehicle

- Inspect all visible parts of chassis frame.



Major defect if one of the components of the chassis frame is broken in a way that it comes in contact with a moving part or with the body.

Trailer Hitch (Coupling Device)

Tractor-semitrailer

The same type of hitch can be found on a road train.

INSPECTION PROCEDURE

13.1 CHECK TO MAKE SURE FIFTH WHEEL IS FIRMLY ANCHORED

On each side of the tractor

- Visually inspect the fifth wheel where it is anchored to the tractor's chassis frame.

OBSERVABLE DEFECT CATEGORY

Components: fifth wheel anchorages



Major defect if:

- over 20% of the parts anchoring the fifth wheel to the chassis frame are missing or loose;
- 25% or more of the anchorages on a sliding fifth wheel are missing or not working.

13.2 CHECK CONDITION OF FIFTH WHEEL

On each side and at the back of the tractor

- Visually inspect the fifth wheel.

Component: fifth wheel



Major defect if fifth wheel is cracked, misshapen or worn to the point where there is a risk of a breakaway.

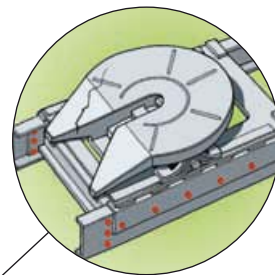
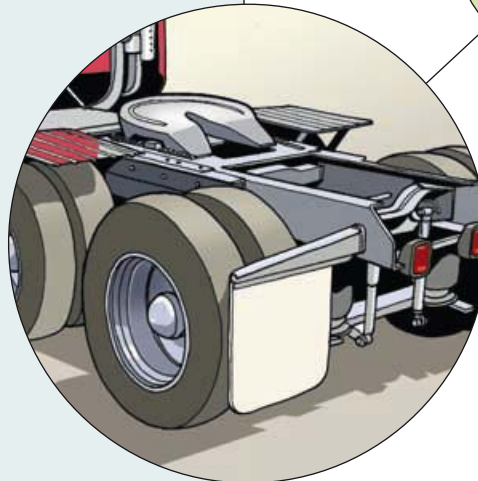



INSPECTION PROCEDURE

OBSERVABLE DEFECT CATEGORY

13.3 CHECK CONDITION OF UPPER PLATE AND TRAILER KINGPIN

Components: upper plate and kingpin

At front of semitrailer

- Visually inspect upper plate and trailer kingpin.



Major defect if upper plate or trailer kingpin is poorly anchored, cracked, bent or damaged to the point where there is a risk of a breakaway.

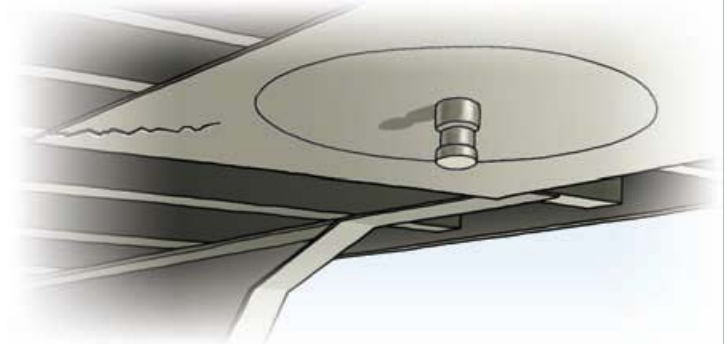

13.4 CHECK HITCHING

Components: fifth wheel jaws and locking indicator

Behind the tractor

- Check to make sure fifth wheel jaws are completely closed.

On the side of the tractor

- Check the locking indicator at the front and on the side of the fifth wheel. If there is no indicator, check the position of the unlocking knob.



Major defect if:

- The jaws are not completely closed behind the kingpin;
- The locking mechanism for the jaws is not engaged.

Truck-trailer

The same type of hitch can be found on A or C road trains.

INSPECTION PROCEDURE

OBSERVABLE DEFECT CATEGORY

13.5 CHECK CONDITION OF PINTLE HOOK

Component: pintle hook

At the back of the truck or at the end of the trailer drawbar

- Visually inspect pintle hook.



Major defect if:

- The hook is poorly anchored, cracked or damaged to the point where there is a risk of a breakaway;
- The locking mechanism for the hook is missing or does not work.

13.6 CHECK CONDITION OF DRAWBAR

Component: drawbar

In front of trailer

- Visually inspect drawbar.



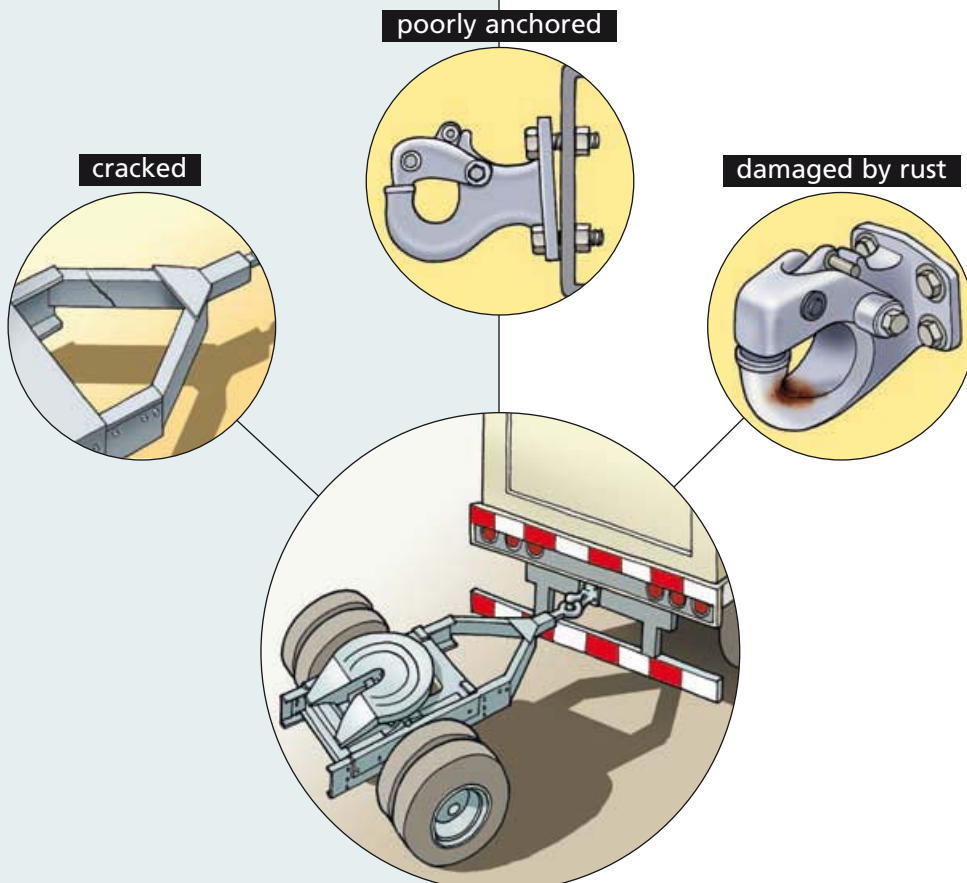

Major defect if the drawbar is poorly anchored, cracked or damaged to the point where there is a risk of a breakaway.



Load Securement



INSPECTION PROCEDURE	OBSERVABLE DEFECT CATEGORY
<p>14.1 CHECK TO SEE IF LOAD IS PROPERLY SECURED</p> <p><u>Everything is checked either inside the load space or outside this space, depending on the type of vehicle body.</u></p> <p>If vehicle is empty:</p> <ul style="list-style-type: none"> • Visually inspect panels, posts, doors and side rails. 	<p>Components: panels, posts, doors or side rails</p> <p> Offence¹ if:</p> <ul style="list-style-type: none"> • A panel, post, door or side rail is not firmly anchored to the vehicle. <p><small>¹ This is an offence under section 471 of the Highway Safety Code. The driver is liable to a fine of \$200 to \$300.</small></p>
<p>If vehicle is loaded, in addition to the above:</p> <ul style="list-style-type: none"> • Visually inspect securing devices and systems to make sure they comply with standards. 	<p>Components: SECURING DEVICES AND SYSTEMS (blocks, chains, tie-downs, hooks, tarpaulin, canvas, etc.)</p> <p> Offence¹ if:</p> <ul style="list-style-type: none"> • A panel, post, door or side rail is not firmly anchored to the vehicle; • The load is not secured or covered well enough and there is a risk of its shifting or falling off the vehicle; • The load is positioned, secured or covered in a manner that reduces the driver's field of vision, interferes with the stability or handling of the vehicle or blocks the lights or headlights. <p><small>¹ This is an offence under section 471 of the Highway Safety Code. The driver is liable to a fine of \$200 to \$300.</small></p>



Occupational injuries



At least 80% of occupational injuries sustained by heavy vehicle drivers occur when drivers are not behind the wheel; for example, while getting out of the cab, while handling or transferring cargo, during pre-trip inspections or while securing loads. This section discusses the occupational hazards of pre-trip inspections and how to avoid injury.

If a driver feels that a vehicle has defects that could endanger his health or safety, he may refuse to drive it, despite being ordered to do so. For further information in this regard, contact the Commission de la santé et de la sécurité du travail (CSST), for businesses under provincial jurisdiction (see page 60), or the Labour Directorate of Human Resources Development Canada, for businesses under federal jurisdiction (see page 60).

<p>REFUSAL TO PERFORM WORK IN BUSINESSES UNDER PROVINCIAL JURISDICTION</p>	<p>“A worker has a right to refuse to perform particular work if he has reasonable grounds to believe that the performance of that work would expose him to danger to his health, safety or physical well-being, or would expose another person to a similar danger.”</p> <p>Act respecting occupational health and safety, s. 12</p>
<p>REFUSAL TO PERFORM WORK IN BUSINESSES UNDER FEDERAL JURISDICTION</p>	<p>“Subject to this section, an employee may refuse to use or operate a machine or thing, or to work in a place if the employee has reasonable cause to believe that:</p> <ul style="list-style-type: none"> a) The use or operation of the machine or thing constitutes a danger to the employee or another employee, or b) A condition exists in the place that constitutes a danger to the employee.” <p>Canada Labour Code, Part II, s. 128</p>

Occupational hazards of pre-trip inspections and how to avoid injury



WHEN CHECKING UNDER THE HOOD¹

Hazards

- Slipping on mud or ice in footholds on bumpers;
- Falling while raising the hood;
- Injuring your back (by grasping hood, slipping, falling);
- Having the hood or cab fall on you;
- Touching a hot part in the engine compartment and being burned.

¹ Avoid tilting the cab unless there are no panels allowing access to components for inspection.





How to prevent injury

When the engine compartment is under the hood

- Before opening the hood, make sure the footholds on the bumper are free of material that might cause you to slip;
- Before opening the hood, test it to make sure it is not stuck due to ice or heat;
- When the hood is open, make sure it will stay in that position;
- Where possible, avoid standing on the tire when doing a check. Try to stand on a flat surface;
- When the engine is running, perform only a visual inspection; Do not put your hand in the engine compartment: you could burn it on a hot part or catch it in a belt.

When the engine compartment is under a tilt cab¹

- Stand far enough back that you will not be hit by the cab when tilting it open or shut;
- Block the cab if there is no safety device to prevent it from falling in the event of a pressure burst.

¹ Avoid tilting the cab unless there are no panels allowing access to components for inspection.

When the engine compartment has doors

- Make sure the doors to the engine compartment are fully open and locked in place.

**OPENING THE HOOD...
...WITHOUT HURTING
YOUR BACK**

When unlocking the hood, lift each corner to make sure it is not stuck. You will not have to force so hard when tilting the hood open.

**MOST OCCUPATIONAL
INJURIES OCCUR WHEN
THE DRIVER IS BEHIND
THE WHEEL.**

True or False?

Answer: False





WHEN GETTING IN AND OUT OF YOUR VEHICLE

Hazards

- Falling or slipping while getting in or out of your vehicle, resulting in a back injury, sprain or bruising.

How to avoid injury

- Use the grab handles instead of the door handles to hang on to;
- Make sure the running boards are free of any material that could cause you to slip (mud, ice, etc.);
- Install non-slip running boards that are wide enough to provide adequate foot support (over 18 cm);
- Apply the “3-point support” principle (rest on three fulcrums) when getting in and out of the cab;
- Step down backwards rather than jumping out;
- Avoid placing obstacles (e.g. shoe brush) in footrests;
- Never use the steering wheel to support yourself. Use a stationary object instead, such as a grab handle.



TO AVOID FALLING WHEN GETTING OUT OF THE CAB, YOU SHOULD:

- A) Jump out
- B) Step down backwards, using three support points
- C) Make sure the running boards are free of obstacles

Answer: B and C



WHEN CHECKING OUTSIDE THE VEHICLE

Hazards

- Being hit by a moving vehicle;
- Falling from loss of one's balance on a slippery or uneven surface.

How to avoid injury

- Set the parking brake;
- Make sure the parking area is adequate:
 - level surface free of snow or ice;
 - area well lighted so as to make uneven ground visible;
 - out of wind and traffic.

**GREATER VISIBILITY
=
GREATER SAFETY**

- Conduct your check in a well-lit place that has a level surface and is away from traffic.
- If it is dark out, use a flashlight so you can see better.
- If possible, wear reflectorized clothing during roadside inspections.





WHEN INSPECTING THE TRAILER HITCH

Hazards

- Slipping, falling or banging against a stationary object while unlocking the fifth wheel;
- Slipping or falling while climbing onto or down from the platform providing access to coupling devices;
- Slipping or falling while plugging in the electricity or connecting trailer brake hoses;
- Straining yourself while turning the crank handle to lift the landing gear.

How to avoid injury

- Use a hook whose loop is long enough and sufficiently curved that you do not have to stretch or will not lose your balance when unlocking the fifth wheel;
- If you are unable to connect trailer brake hoses from the ground, install metal grating as far as the base of the fifth wheel so that you have a flat, non-skid surface to stand on;
- Consider installing handrails or grab handles to provide you with three fulcrum points;
- Place yourself parallel to the semitrailer, with the leg next to the vehicle behind you for support. Place the crank so as to minimize effort and prevent strain.



Pre-trip inspection in Canada and the United States

Pre-trip inspections are common practice throughout North America. However, the related requirements and procedure may differ from one province, state or country to the next. Below are the addresses and telephone numbers of the principal organizations responsible for pre-departure inspection.

Government of Newfoundland and Labrador

Works, Service and Transportation
5th Floor Confederation Building
St. John's (Terre-Neuve) A1B 4J6
Telephone: (709) 729-2300
Fax: (709) 729-4658
E-mail: info@gov.nf.ca

Government of Prince Edward Island

Transportation and Public Works
Highway Safety Operations
P.O. Box 2000
Charlottetown
(Île-du-Prince-Édouard) C1A 7NB
Telephone: (902) 368-5231
Fax: (902) 368-5236

Government of Nova Scotia

Road Safety Programs
Department of Transportation
and Public Works
1505 Barrington Street
Halifax (Nouvelle-Écosse) B3G 3K5
Telephone: (902) 424-1550
(902) 424-1517
Fax: (902) 424-0772

Government of New Brunswick

Commercial Vehicle Enforcement
P.O. Box 6000
Fredericton (Nouveau-Brunswick)
E3B 5H1
Telephone: (506) 453-7157

Moncton inspection station

Telephone: (506) 856-2860
Fax: (506) 856-2865

Edmundston Inspection Station

Telephone: (506) 737-4119
Fax: (506) 735-2545

Government of Ontario

MTO:
Information: 1 800 268-4MTO (686)
301 St. Paul Street
St. Catharines (Ontario) L2R 7R5
Telephone: (905) 704-2503
E-mail: Bill.cann@mto.gov.on.ca

Government of Manitoba

Manitoba Highways and
Transportation
Compliance Services
1550 Dublin Street
Winnipeg (Manitoba) R3E 0L4
Telephone: (204) 945-3890
Fax: (204) 948-2078

Government of Saskatchewan

Carrier & Shipper Services:
Brian Johnson – Manager
2nd Floor Lancaster Place
2174 Airport Drive
Saskatoon (Saskatchewan) S7K 2H6
Telephone: (306) 933-5293
Fax: (306) 933-5276
E-mail:
brian.johnson.hi0@govmail.gov.sk.ca

Government of British Columbia

Ministry of Transportation
and Highways
Compliance Programs
and Safety Standards
P.O. 9850 STN PROV GOVT
Victoria (Colombie-Britannique)
V8W 9T5

ICBC Compliance Programs

and Safety Standards
Telephone: (250) 414-7848 or 7849
Fax: (250) 978-8018

U.S. Department of Transportation

Federal Highway Administration
Office of Motor Carriers
Division Programs Specialist
Telephone: (802) 828-4480



ASSOCIATION SECTORIELLE TRANSPORT ENTREPOSAGE (ASTE)

The Association Sectorielle Transport Entreposage (ASTE) is a joint industry board established in 1982 for the purpose of helping employers and workers in the transportation and storage sectors eliminate occupational health and safety hazards. To this end, the ASTE offers four types of services:

- Training;
- Information;
- Technical assistance and advice;
- Research.

The ASTE offers a four-hour training session on pre-trip inspections, including major and minor defects, health and safety hazards associated with pre-departure checks, and highlights of the regulations in effect. The course is aimed at drivers, carriers, mechanics and employer/employee representatives.

To contact the ASTE:

By mail: Association Sectorielle Transport Entreposage
6455, rue Jean-Talon Est
Bureau 301
Montréal (Québec) H1S 3E8

By phone: (514) 955-0454 or 1 800 361-8906

By fax: (514) 955-0449

By e-mail: info@aste.qc.ca

Web site: www.aste.qc.ca





**REGIONAL OFFICES OF THE CSST
(businesses under provincial jurisdiction)**

ABITIBI-TÉMISCAMINGUE	Rouyn-Noranda	Tel. (819) 797-6191	1 800 668-2922
	Val-d'Or	Tel. (819) 354-7100	1 800 668-4593
BAS-SAINT-LAURENT	Rimouski	Tel. (418) 725-6100	1 800 668-2773
CHAUDIÈRES-APPALACHES	Saint-Romuald	Tel. (418) 839-2500	1 800 668-4613
	CÔTE-NORD	Sept-Îles	Tel. (418) 964-3900
ESTRIE	Baie-Comeau	Tel. (418) 294-7300	1 800 668-0583
	Sherbrooke	Tel. (819) 821-5000	1 800 668-3090
GASPÉSIE— ÎLES-DE-LA-MADELEINE	Gaspé	Tel. (418) 368-7800	1 800 668-6789
	New-Richmond	Tel. (418) 392-5091	1 800 668-4595
ÎLE-DE-MONTRÉAL	Montréal	Tel. (514) 873-3990	
LANAUDIÈRE	Joliette	Tel. (450) 753-2600	1 800 461-4489
LAURENTIDES	Saint-Jérôme	Tel. (450) 431-4000	1 800 465-2234
LAVAL	Laval	Tel. (450) 967-3200	
LONGUEUIL	Longueuil	Tel. (450) 442-6200	1 800 668-4612
MAURICIE—CENTRE-DU-QUÉBEC	Trois-Rivières	Tel. (819) 372-3400	1 800 668-6210
OUTAOUAIS	Gatineau	Tel. (819) 778-8600	1 800 668-4483
QUÉBEC CITY	Québec City	Tel. (418) 266-4000	1 800 668-6811
SAINT-JEAN-SUR-RICHELIEU	Saint-Jean-sur-Richelieu	Tel. (450) 359-2100	1 800 668-2204
SALABERRY	Salaberry-de-Valleyfield	Tel. (450) 377-6200	1 800 668-2550
SAGUENAY—LAC-SAINT-JEAN	Chicoutimi	Tel. (418) 696-5200	1 800 668-0087
	Saint-Félicien	Tel. (418) 679-5463	1 800 668-6820
YAMASKA	Saint-Hyacinthe	Tel. (450) 771-3900	1 800 668-2465
	Granby	Tel. (450) 378-7971	
	Sorel	Tel. (450) 743-2727	



FOR FURTHER INFORMATION

Société de l'assurance automobile du Québec

333, boul. Jean-Lesage, case postale
19600, Québec (Québec) G1K 8J6

Québec (city and vicinity):
(418) 643-7620

Montréal:
(514) 873-7620

Elsewhere in Québec:
1 800 361-7620

- Conduct review policy
- Driver's licence
- Vehicle registration
- Pre-trip inspection
- Mandatory periodic mechanical inspection
- Preventive Maintenance Program
- Driving and duty time
- Monitoring of road transport
- Special permits (classes 1 to 7)
- Status of heavy vehicle owner's or operator's record
- Publications

Web site:
www.saaq.gouv.qc.ca

Commission des transports du Québec

200, chemin Sainte-Foy, 7^e étage
Québec (Québec)
545, boul. Crémazie Est
Bureau 1000
Montréal (Québec) H2M 2V1

- **Registration and renewal of registration in the *Registre des propriétaires et des exploitants de véhicules lourds***
- Safety rating, measures and sanctions
- List of transport service intermediaries
- Bus transport permits
- Register of bulk carriers
- Brokerage permit for bulk trucking services

Telephone:
Anywhere in Québec:
1 888 461-2433

Fax:
Québec City:
(418) 644-8034

Montréal:
(514) 873-4720

Web site:
www.ctq.gouv.qc.ca

Ministère des transports

Direction des communications
700, boul. René-Lévesque Est
27^e étage
Québec (Québec) G1R 5H1

Inforoutière:
1 888 355-0511 or
#0511

Fax:
Québec City:
(418) 643-1289

Montréal:
(514) 873-4730

- Operation of trucks on the road network
- Load and size limits
- Special permits
- Load-securing standards
- Transportation of dangerous substances
- Bulk trucking
- Harmonization of trucking regulations in North America

Web site:
www.inforoutiere.qc.ca

